

CUBIC

8 000 h / 105°C

10 V ... 400 V	100 μ F ... 33 000 μ F	35 x 35 x 16	- 55°C + 105°C	Long Life Time
450 V	100 μ F ... 220 μ F	35 x 50 x 16	- 55°C + 85°C	



APPLICATIONS

- Low profile printed circuit mounting
- Possible thermal dissipation per conduction through lower and upper surface
- Switch mode power supplies, impulse current

Aluminum case : Tin coated leads

Negative pole marked

Tolerance on capacitance at 20°C : $\pm 20\%$

Operating temperature : - 55°C + 105°C

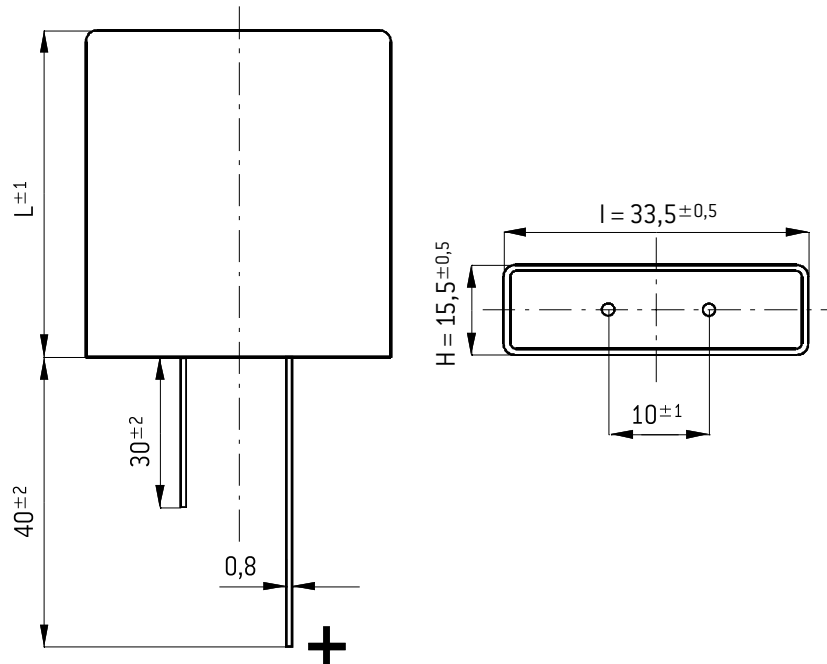

SPECIFICATIONS

CECC 30300 Long life

IEC 60 384-4 Long life

DIN 41 240 climatic category : - 55 + 105°C

and GPF : - 55°C + 105°C / 56 days

- 55°C + 85°C / 56 days

RESISTANCE TO VIBRATIONS

Frequency range : 10 – 2000 Hz

Displacement amplitude : 1.5 mm

or max acceleration : 20 g – 196 m/s²

Duration : 3 x 2 hours

8 000 h / 105°C

Capacitance (μF)	Case			Tan δ 100 Hz +20°C max. (%)	ESR 100 Hz +20°C max. Typic (m Ω)	Z 10 kHz +20°C Typic (m Ω)	I +20°C 5 min. max. (mA)	I \sim 100 Hz		Code
	I (mm)	L (mm)	H (mm)					+40°C max. (A)	+105°C - U _R < 450 V +85°C - U _R = 450 V (A)	
Rated voltage 10 V										
15000	35	35	16	28	20	18	0,90	16,8	4,5	A 710000
22000	35	50	16	35	17	14	1,30	20	5,8	A 710001
33000	35	50	16	47	15	11	1,98	20	6,1	A 710002
Rated voltage 16 V										
10000	35	35	16	18	19	17	0,96	17,3	4,7	A 710020
15000	35	35	16	25	18	15	1,40	18	4,8	A 710022
22000	35	50	16	30	16	13	2,10	20	5,9	A 710021
Rated voltage 25 V										
6800	35	35	16	17	27	19	1,00	14,5	3,9	A 710040
10000	35	50	16	17	18	15	1,50	20	5,6	A 710041
15000	35	50	16	21	15	13	2,20	20	6,1	A 710042
Rated voltage 35 V										
5600	35	35	16	14	27	19	1,20	14,5	3,9	A 710060
6800	35	35	16	15	24	17	1,40	15,4	4,1	A 710061
10000	35	50	16	17	19	13	2,10	20	5,5	A 710062
Rated voltage 40 V										
4700	35	35	16	12	26	18	1,10	15	4	A 710080
6800	35	50	16	13	21	13	1,60	19	5,2	A 710081
Rated voltage 50 V										
3300	35	35	16	10	33	26	0,99	13	3,5	A 710100
5000	35	35	16	10	20	12	1,50	17	4,5	A 710101
8200	35	50	16	15	20	12	2,50	20	5,3	A 710102
Rated voltage 63 V										
2200	35	35	16	10	42	25	0,83	12	3,2	A 710120
3300	35	50	16	10	31	20	1,20	16	4,3	A 710121
4700	35	50	16	12	28	18	1,80	17	4,5	A 710122
Rated voltage 80 V										
1500	35	35	16	10	52	30	0,72	10,4	2,8	A 710140
2200	35	50	16	10	43	17	1,10	13,6	3,6	A 710141
Rated voltage 100 V										
1000	35	35	16	10	51	35	0,60	10,8	2,8	A 710160
1500	35	50	16	10	36	23	0,90	14,9	4	A 710161
1800	35	50	16	10	29	19	1,1	16,6	4,4	A 710162
Rated voltage 160 V										
470	35	35	16	11	170	130	0,45	5,8	1,6	A 710180
680	35	50	16	11	150	110	0,66	7,3	1,9	A 710181
Rated voltage 200 V										
330	35	35	16	12	250	160	0,39	4,8	1,3	A 710200
470	35	50	16	12	160	120	0,56	7,1	1,9	A 710201
680	35	50	16	12	150	110	0,81	7,3	1,9	A 710202
Rated voltage 250 V										
330	35	35	16	12	260	170	0,50	4,7	1,3	A 710220
470	35	50	16	12	160	120	0,70	7,1	1,9	A 710221
Rated voltage 350 V										
220	35	35	16	10	280	130	0,46	4,6	1,2	A 710240
330	35	50	16	10	180	80	0,69	6,6	1,8	A 710241
Rated voltage 400 V										
100	35	35	16	10	420	260	0,80	3,8	1	A 710260
150	35	35	16	10	280	150	1,00	4,6	1,2	A 710262
220	35	50	16	10	200	130	1,20	6,3	1,7	A 710261
Rated voltage 450 V										
100	35	35	16	10	600	320	0,80	3,1	0,8	A 710280
150	34	50	16	10	420	220	1,00	4,4	1,2	A 710281
220	35	50	16	10	300	160	1,30	5,2	1,4	A 710282

CUBIC

8 000 h / 105°C

EXPECTED LIFE

as a function of temperature and ripple current

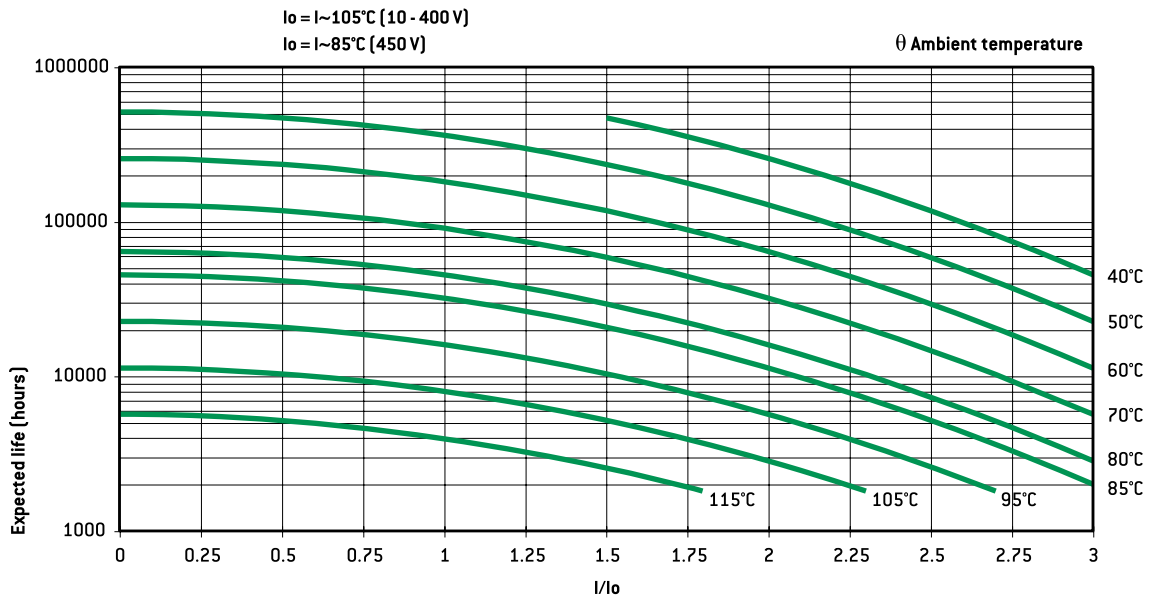

PERMISSIBLE RIPPLE CURRENT I (R.M.S. VALUE)

versus frequency f :

I ~ : permissible r.m.s. current at 100 Hz

f (Hz)	50	100	300	600	1 000	10 000	≥ 50 000
I	0,8 x I~	I~	1,2 x I~	1,3 x I~	1,35 x I~	1,5 x I~	1,6 x I~

General technical data

1. BASIC CONSTRUCTION

Structure of an electrolytic aluminum capacitor is shown hereunder :

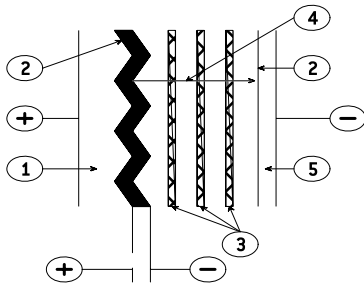

1. Anode : aluminum foil
2. Dielectric : aluminum oxide
3. Papers spacers impregnated with electrolyte
4. Ionic conduction assumed by electrolyte
5. Cathode : aluminum foil

The positive plate is an etched aluminum foil covered with alumina which is the dielectric of the capacitor.

The negative plate is constituted by a second aluminum foil which serves as a current supply, and by electrolyte-impregnated papers layers.

The metal used for anode is a $\geq 99,98\%$ grade aluminum.

The dielectric has a thickness of $13 \text{ \AA} / \text{V}$.

The aluminum used for the cathode is a $\geq 98\%$ grade aluminum covered with a dielectric layer with a thickness of about 40 \AA .

2. DIAGRAM OF THE EQUIVALENT CIRCUIT

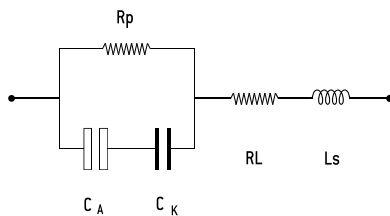

- C_A = Capacitance of the anode
- C_K = Capacitance of the cathode
- R_p = Parallel resistance due to the aluminum oxide film.
- R_L = Series resistance of connections, plates and impregnated spacer.
- L_s = Inductance of winding and connections.

A standard simplified diagram is.

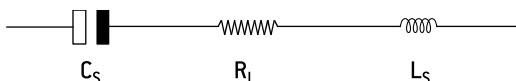

C_s is the series capacitance of both anode and cathode capacitances. Electrolytic aluminum capacitors are naturally polarized because of the insulating film on the anode. Given the very thin aluminum oxide layer, a reversed voltage should not exceed 1.5 V when there is energy supply.

Short duration reverse voltages can be absorbed by special construction, second anode replacing the former cathode.

3. CAPACITORS MARKING

3.1. ARTICLE CODE (ON EACH PACKAGING)

A followed by 6 figures number. First 3 positions are specific of the range. (Ex. A 745xxx for a FELSIC 85 BD)

140	FELSIC en batterie / in bank	741	FELSIC 125 FRS BD (ex 731)
701	PRORELSIC 125	742	PRORELSIC 105 TFRS
703	PRORELSIC 125	743	PRORELSIC 105 TFRS
704	SNAPSIC	744	FELSIC 85 BC / FELSIC 85 LP
705	SNAPSIC 105	745	FELSIC 85 BD
706	FELSIC HP BC – BD	746	FELSIC 85 M BC
708	PRORELSIC 145	747	FELSIC 85 M BD
710	CUBISIC	748	SICAL CO 42 - SICAL
711	PROMISIC 031	749	SICAL CO 42 - SICAL
712	CUBISIC LP	750	CUBISIC 125
713	SNAPSIC 105 LP	756	FELSIC 105 BC / FELSIC 105 LP
714	SNAPSIC 4P	757	FELSIC 105 BD
715	SNAPSIC 105 4P	760	FELSIC CAPAX BC
716	SNAPSIC HV	761	FELSIC CAPAX BD
717	SNAPSIC CAPAX	762	FELSIC 105 TFRS BC
718	SNAPSIC 125	763	FELSIC 105 TFRS BD
721	RELSIC 033	764	FELSIC HV BC
722	CI FRS	765	FELSIC HV BD
723	CI FRS	775	VACSIC
728	FELSIC 039 (ex 727) - FELSIC DI	774	VACSIC 150
738	FELSIC 037 (ex 737)	776	ALSIC 20G / ALSIC 145 20G
740	FELSIC 125 FRS BC (ex 731)		

In FELSIC ranges, article code without first letter A, is printed on each capacitor. a Figure 9 in fourth position shows a special product.

3.2. BATCH (ON EACH CAPACITOR).

3 figures or 6 figures

3.3. DATE (ON EACH CAPACITOR IF APPLICABLE)

4 figures (year-week)

4. ELECTRICAL CHARACTERISTICS

4.1. RATED CAPACITANCE C_R

The rated capacitance is defined at 100 Hz and at ambient temperature.

4.2. RATED VOLTAGE U_R

U_R is the maximum DC voltage which may be applied in continuous operation. When applying a superimposed alternating voltage, the peak value of the resulting waveform should not exceed the rated voltage.

4.3. PEAK VOLTAGE U_p

U_p is the maximum repetitive voltage which can be applied within short periods. Defined in CECC 30 300 and IEC 60 384-4 :

1000 cycles of 30 s charge followed by a no load period of 5 min. 30 s with upper category temperature.

$$U_p \geq 1,15 U_R (U_R \leq 315 \text{ V})$$

$$U_p \geq 1,10 U_R (U_R > 315 \text{ V})$$

General technical data

4.4. DISSIPATION FACTOR $\tan\delta$

The dissipation or loss factor is defined by its tangent $\tan\delta$

$$\tan\delta = R_s C_s \omega$$

$$(\omega = 2\pi F)$$

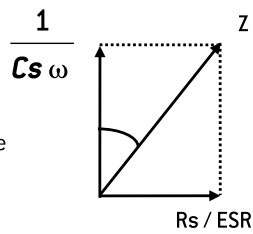

ESR Capacitor Equivalent Series Resistance

Cs Capacitor capacitance

F Frequency [100 Hz]

Z Capacitor impedance

4.5. EQUIVALENT SERIES RESISTANCE ESR

The relation between ESR and dissipation factor $\tan\delta$ is given in § 4.4.

4.6. IMPEDANCE Z - INDUCTANCE L

The impedance is given by :

$$Z = \sqrt{R^2 + \left(L\omega - \frac{1}{C\omega}\right)^2}$$

L inductance. Generally L = 5 to 20 nH

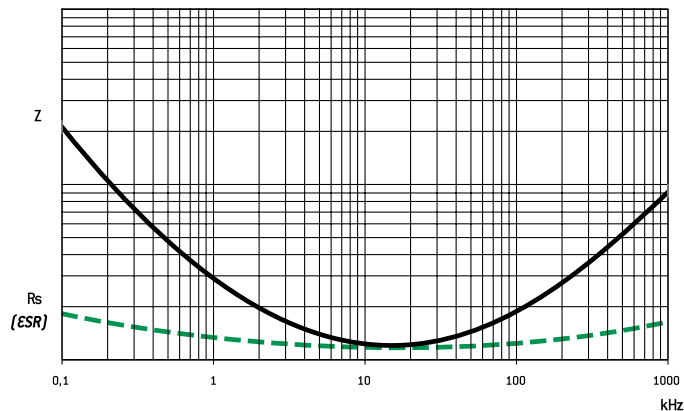

Z and ESR as function of frequency typically follows the chart :

4.7. PERMISSIBLE RIPPLE CURRENT (I r.m.s.) I~

The current is defined at the maximum climatic category and at 100 Hz. It is the root mean square value r.m.s. The value I_0 is the rated value for calculations of expected life up to 3 I_0 .

4.8. LEAKAGE CURRENT II

It is measured at 20°C after a 5 min. polarization under rated voltage.

For C_R in μF and U_R in V :

$$I \leq 0,01 C_R U_R \text{ or } 1 \mu A^*$$

when $C_R U_R \leq 1000 \mu C$

$$I \leq 0,006 C_R U_R + 4 \mu A$$

when $C_R U_R > 1000 \mu C$

For $U_R > 350 V_{DC}$ it can be specified :

with $K = 4, 6 \text{ or } 8$

or

$$I \leq 0,3 (C_R U_R)^{0,7} + 4 \mu A \text{ (CECC 30 300)}$$

* Whichever is the greater

4.9. CHARACTERISTICS

Versus temperature (typical values).

4.9.1. Capacitance drift

Versus temperature

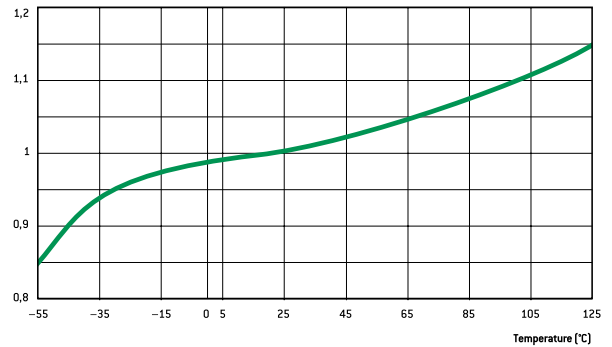

4.9.2. ESR and Z drifts at 100 Hz

Versus temperature

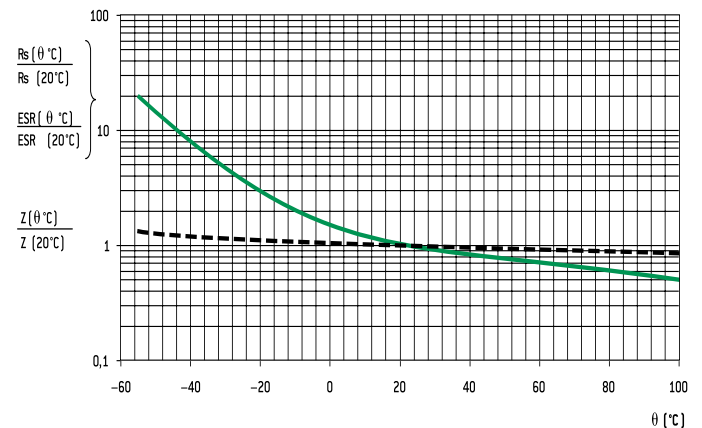

4.9.3 Leakage current drift

Versus temperature

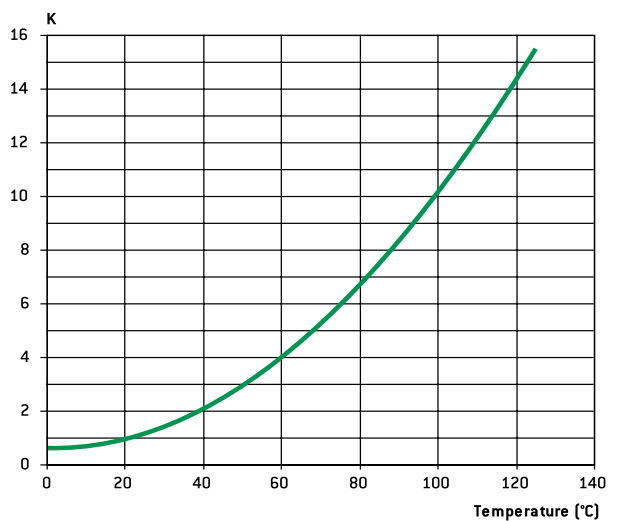

General technical data

5. SPECIFICATION TO APPLY

Electrolytic aluminum capacitors are defined in :

- NF and UTE French national standard
- CECC European specifications
- IEC international specifications

Quality insurance procedures are described in these specifications.

	French	European	International
Generic specification Fixed capacitors	NF C 83 100	CECC 30 000 EN 130 000	IEC 60 384 -1 QC 300 000
Sectional specification Electrolytic aluminum capacitors	NF C 83 110	CECC 30 300	IEC 60 384 - 4 C 300 300
Blank deta II specification - Electrolytic aluminum capacitors with non solid electrolyte /	UTE 83 110	CECC 30 301	IEC 60 384 - 4 -1 QC 300 301
Blank deta II specifications	CECC 30 301- 017 to CECC 30 301- 062 CO 31 to CO 55	CECC 30 301- 017 to CECC 30 301- 062 CECC 30 301- 802 to CECC 30 301- 811	

6. ENDURANCE TESTS / LIFE TIME

6.1. STANDARD ENDURANCE TEST

at max category temperature :

Temperature	Endurance test			
	Grade I - Long life			Grade II - General purpose
	10 000 h	5 000 h	2 000 h	1 000 h
125°C			•	
105°C		•	•	•
85°C	•	•	•	•

Standard endurance tests do not exceed 2000 hours at 125°C. However, present EXXELIA^{SIC SAFCO} technologies concerning liquid electrolytes have led to endurance tests up to 5000 hours at 125°C (PRORELSIC 125 - FELSIC 125 RS) and even 20000 hours at 125°C (PRORELSIC 145 - ALSIC 145)

6.2. PERFORMANCE REQUIREMENTS ON STANDARD ENDURANCE TESTS.

Permissible capacitance drift $\Delta C/C$ (%)

Permissible increase factors on $\tan\delta$, ESR, Z and II initial values

U_R	Endurance test			
	Grade I			Grade II
	10 000 h	5 000 h	2 000 h	1 000 h
6,3 V			+15 -30	+25 -40
10 V - 35 V	+15 -20	± 15	± 15	± 30
40 V - 160 V	± 15	± 15	± 15	± 30
> 160 V	± 15	± 10	± 10	± 15

	Endurance test			
	Grade I			Grade II
	10 000 h	5 000 h	2 000 h	1 000 h
$\tan\delta$ or ESR (1)	1,5	1,3	1,3	1,5
Z (2)	3	2	2	3
II	Standard values			

(1) $\tan\delta$ or ESR : for initial value, take standard value.

(2) Z : for initial value, take specified value (see data sheet).

Specific requirements can be taken into consideration with regards to initial values of dissipation factor or equivalent series resistance and impedance.

6.3. FAILURE CRITERIA FOR ELECTROLYTIC CAPACITORS.

Failure criteria are defined in CECC 30 301

- Non measurable defaults leading to complete failure.
- Measurable defaults leading to adjustment losses of the load circuit (failure due to variations).

6.3.1. Non measurable defaults.

They might be summed up as :

- Open circuit
- Short circuit
- Operation of pressure relief device
- Severely damaged insulation
- Unusable terminations

6.3.2. Measurable defaults.

Variations exceeding the values given below characterize a default.

- Capacitance drift $\Delta C/C$ (%) : 3 times the limit for standard endurance testing or 50 % (whichever is the smallest).
- $\tan\delta$ or ESR : 3 times standard max initial values.
- Z : 3 times standard max initial values.
- II : initial limit (under load conditions).

Specific requirements can be taken into consideration with regards to lower drifts.

6.4. INFLUENCE OF MAIN PARAMETER ON OPERATIONAL LIFE.

6.4.1. Temperature.

The capacitors operational life is highly dependent upon its internal temperature Θ_i and therefore upon the ambient temperature and the ripple current.

Knowing ESR and dissipated power values (§ 6.4.3.) one can figure out, the internal temperature rise and then determine the capacitors expected life.

With present high boiling point electrolytes (§ 8.6)

$\Theta_i \text{ max} = 125 \text{ to } 185^\circ\text{C}$ depending on styles.

6.4.2. Ripple current.

The ripple current flowing through the capacitor increase the internal temperature through power dissipation.

Standards define the permissible current at 100 Hz and generally consider a temperature rise of 5 to 10°C of max category temperature.

Current waveforms and frequencies make it difficult to clearly determine the capacitors internal temperature rise, which defines the operationally life.

Experiments confirm following relationship :

$$\Theta_i = \Theta_a + (\Theta_c - \Theta_a) K$$

Where :

- Θ_i = Internal hot spot temperature
- Θ_a = Ambient temperature
- Θ_c = Case temperature
- K = Parameter depending upon case diameter and cooling
 - $\emptyset \geq 51 \text{ k} = 2^{\pm 0,5}$
 - $\emptyset < 51 \text{ k} = 1,5^{\pm 0,5}$ (air cooling - 0,2 m/s)

General technical data

r.m.s. value according to current waveform.

Function	Mean value	R.m.s. value	Function	Mean value	R.m.s. value	Function	Mean value	R.m.s. value
	$A (t_0/T)$	$A \sqrt{t_0/T}$		$A/2$	$A \sqrt{3}$		$2A/\pi$	$A / \sqrt{2}$
	$A (t_1/T)$	$A \sqrt{2t_1/3T}$		$2A/\pi (t_0/T)$	$A \sqrt{t_0/2T}$		$A/2$	$A / \sqrt{3}$
	$A/2 (t_0/T)$	$A \sqrt{t_0/3T}$		$A/2 (t_0/T)$	$A \sqrt{t_0/3T}$		0	A

6.4.3. Dissipated power versus case dimension

For calculations of ripple currents, considering an internal temperature rise of 10°C

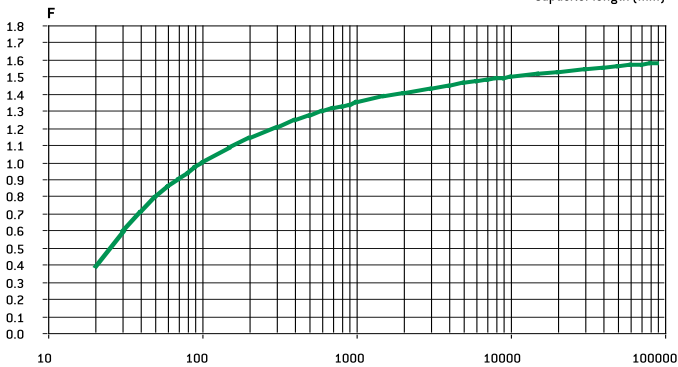
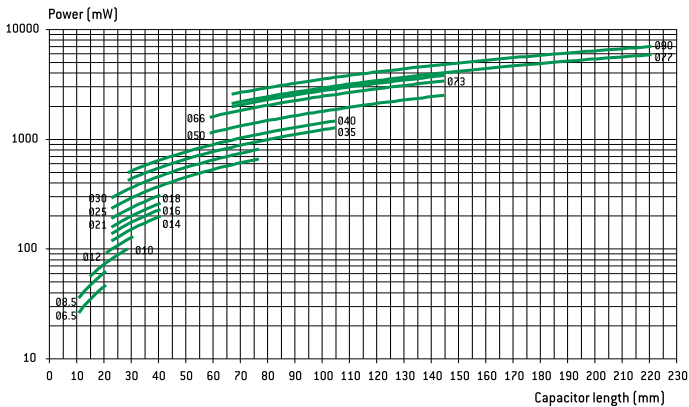

$P = ESR \cdot I^2$

P = Dissipated power (mW)

($\Theta_i - \Theta_a = 10^\circ\text{C}$)

ESR : Equivalent series resistance (100 Hz 20°C)

I : Ripple current (r.m.s. value at 100 Hz)

For different frequencies from 100 Hz, I must be multiplied by the factor F, according to above chart. :

6.4.4. Thermal resistance Rth and air cooling

Rth is static thermal resistance (without cooling) between capacitor central hot spot and ambient temperature measured at a distance of one capacitor diameter

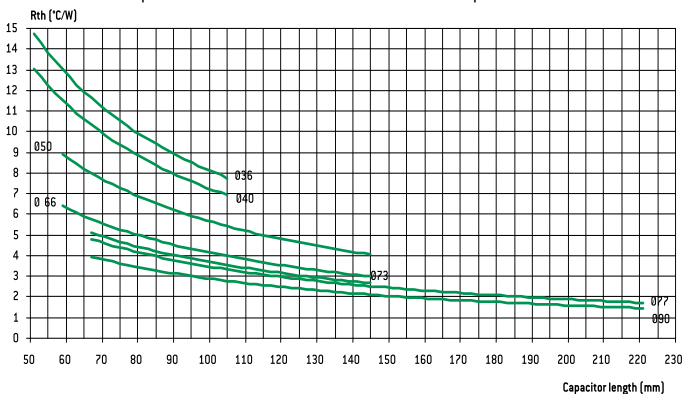

Forced or not cooling air can lead to a significant decrease of these values.

Consequently, r.m.s. ripple current can be increased as a function of air cooling speed :

\emptyset (mm)	$\leq 0,5$ m/s	1 m/s	2 m/s	3 m/s	≥ 4 m/s
66 - 90	1~	1,1 1~	1,2 1~	1,25 1~	1,3 1~
36 - 51	1~	1,2 1~	1,4 1~	1,45 1~	1,5 1~

This parameter shall be applied to one capacitor alone.

For capacitors in bank, ambient temperature must be strictly equal around all capacitors.

6.4.5. Quality guaranty

We guarantee products manufactured during 2 years from the data of shipment against defaults of material and assembly.

This guaranty can be involved by the buyer only if our products are used within normal conditions, always according to the state of the art and taking in account storage conditions.

The equipment design should take into consideration possible failures of our capacitors and related effects in order to avoid them.

Guaranty is not applicable for damages occurred by surge voltage, irregular use, polarity inversion or maintenance default.

Guaranty is exclusively limited to the replacement of individual defective capacitors within the terms of delivery. This rule applied to all cases and particularly to any further consequence of failures.

6.4.6. Reliability

Failure rate :

$$FR = \frac{\text{Number of components tested} \times \text{test duration}}{\text{Number of failures}}$$

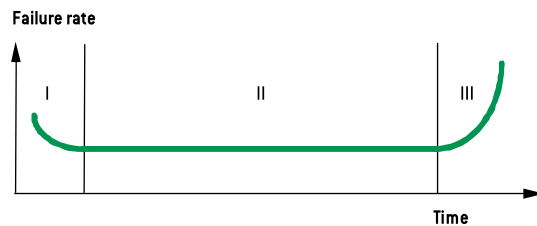

Failure rate is measured in FIT (failure in time = 10^{-9} / hour).

The failure rate is set up during the life time of the capacitor (phase II)

I. Early failure phase (generally excluded during ageing process).

II. Operational life time of the capacitors

III. End of life

General technical data

Mean time between failures MTBF = 1/FR measured in years

Range	Failure rate for a failure percentage not exceeding 1% with a confidence level of 60 %
FELCIC 85 >350 V FELCIC CAPAX > 350 V SNAPCIC - SNAPCIC CAPAX > 350 V SNAPCIC 4P > 350 V PROMISIC 031 Ø = 6,5 SICAL CO 42 - SICAL > 350 V	50 FIT - (MTBF = 2280)
FELCIC 037 - 039 FELCIC 85 ≤ 350 V FELCIC CAPAX ≤ 350 V CUBISIC CI FRS SNAPCIC 105 - SNAPCIC 105 4P SNAPCIC 105 LP - SNAPCIC HV SNAPCIC - SNAPCIC 4P ≤ 350 V SNAPCIC CAPAX ≤ 350 V ALSIC IR - ALSIC 145 - ALSIC HV - VACSIC 150 - VACSIC SICAL CO 42 - SICAL ≤ 350 V PRORELSIC 125 Ø = 6,5 RELSIC 033 PROMISIC 031 Ø > 6,5	25 FIT - (MTBF = 4560)
FELCIC 125 FRS - SNAPCIC 125 FELCIC HV - FELCIC 105	10 FIT - (MTBF = 11410)
PRORELSIC 125 Ø > 6,5 PRORELSIC 145	5 FIT - (MTBF = 22820)

Multiplying factor of FR with voltage and temperature

Factor	Temperature [°C]							
	≤ 40	50	60	70	85	105 (1)	125 (1)	145 (1)
Factor	1	1,5	2,3	3,4	6,3	14	32	72

(1) Only for permitted capacitors

Factor	Percentage of rated voltage (2)		
	100 %	80 %	50 %
Factor	1	0,8	0,5

(2) This voltage has to be constant

Environment	Without vibration		Ground with vibrations or mob ile			
	Ground, fix Controlled air	Ground, fix	PRORELSIC SNAPCIC 20 g FELCIC 20 g	FELCIC 10 g PROMISIC SICAL Ø ≤14	CI FRS - SNAPCIC RELSIC SICAL Ø >14	ALSIC
Factor	1	2	2	4	6	12

7. MANUFACTURING FLOW CHART

Process controls

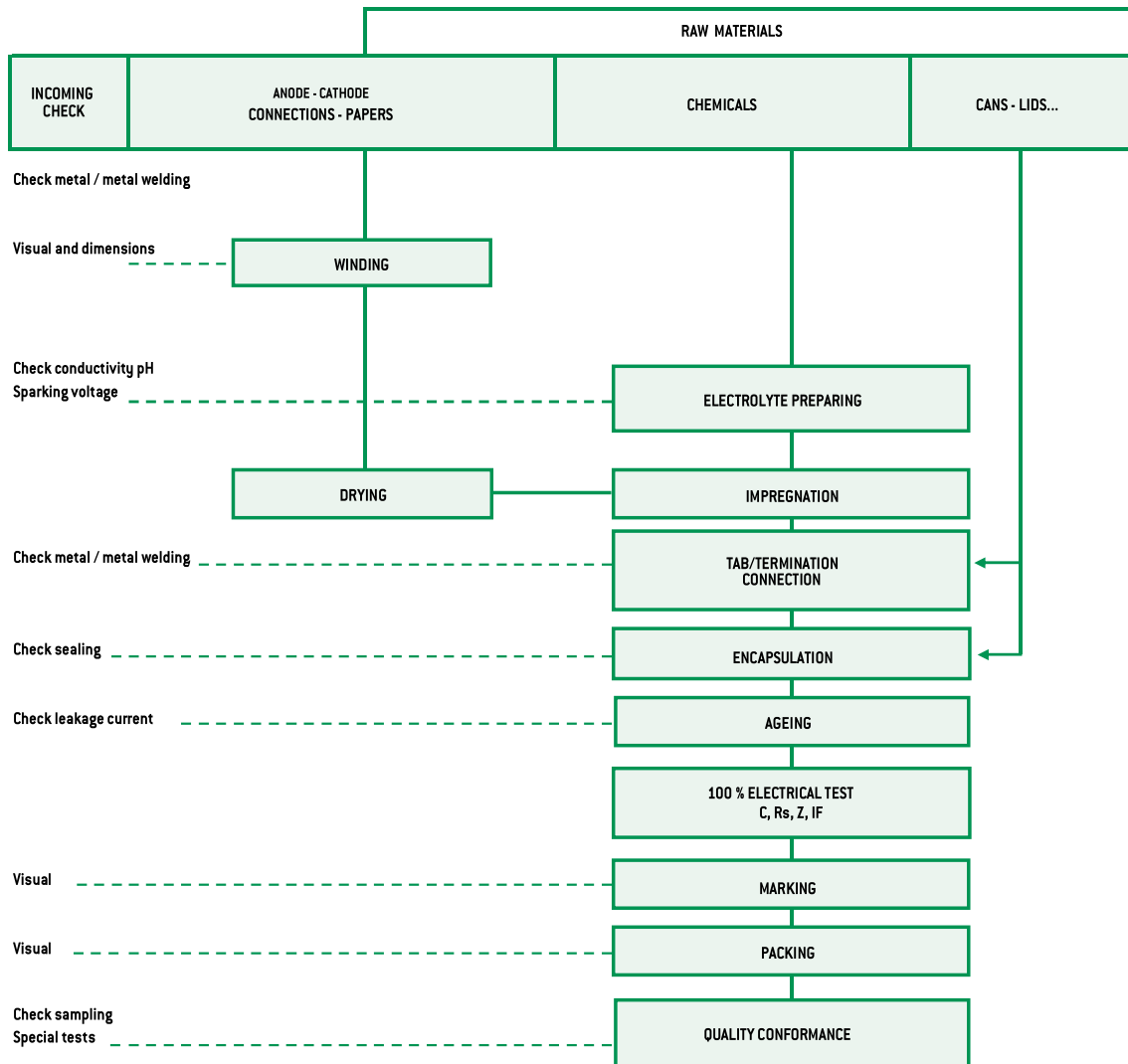

General technical data

8. INFORMATION ON APPLICATION

8.1. CLEANING SOLVENTS

Use aliphatic alcohols, such as denatured ethyl alcohol, isopropanol, or butylacetate, or else alkaline diluted solutions. Avoid incompatible solvents (halogenous for example).

8.2. SHELF LIFE

There is no electrical characteristics variation for long periods of storage except leakage current which can increase.

It is caused by chemical reactions between the dielectric alumina and the electrolyte. These reactions are reversible when switched on. Capacitors can generally be stored at temperature between -5° and $+50^{\circ}\text{C}$ without reforming for the following periods of time :

- For $U_R \leq 100\text{ V}$, storage time : 5 years
(up to 10 years under specific conditions)
- For $100\text{ V} < U_R \leq 360\text{ V}$ storage time : 3 years
- For $360\text{ V} < U_R < 500\text{ V}$ storage time : 1 year
- For $U_R \leq 500\text{ V}$, storage time : 6 months

Generally when these periods are overstepped, one hour at rated voltage causes the decrease of leakage current under the specified limits. An other way to avoid this leakage current increase problem is to always limit available power through capacitor during first seconds or minutes after storage or transport, according to the following chart :

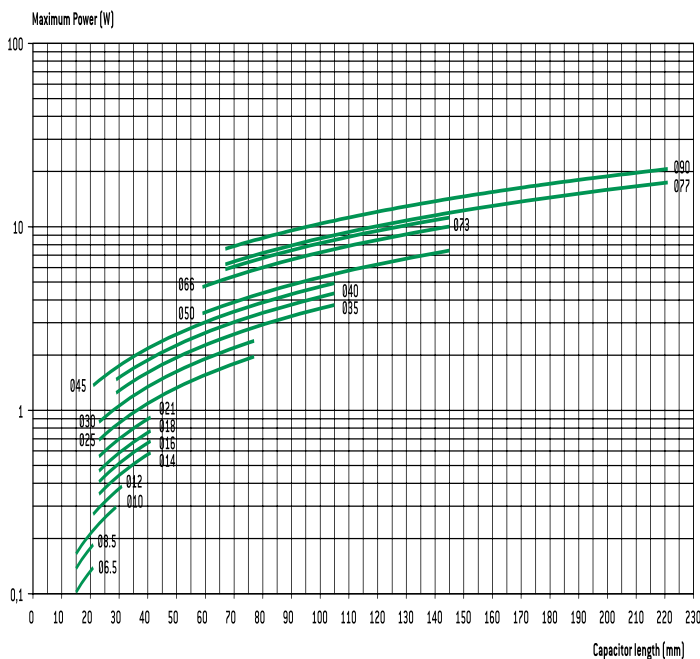

8.3. LOW PRESSURE RESISTANCE

EXXELIA^{SIC SAFCO} capacitors can be used with ambient low pressure decreasing up to 10 mbar (altitude 28000 m – 92000 feet).

8.4. MOUNTING SCREW TERMINALS CAPACITORS (FELSIC)

Capacitors may be used vertically (terminals on top) or horizontally. When used horizontally, the following position in relation to the safety vent, is recommended :

Mounting capacitors in series may be used for operating voltage exceeding U_R . See FELSIC in bank

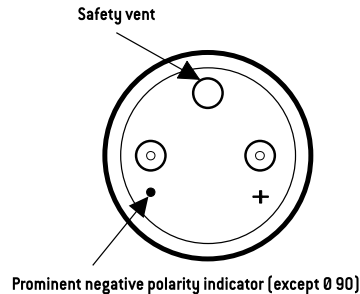

8.5. MOUNTING SOLDER TYPE CAPACITORS.

They may be used in any position. During mounting, avoid applying excessive force to capacitor pins or wires. There is a risk of damaging internal connections. After soldering and for the same reasons, do not try to move the capacitor's body.

8.6. ELECTROLYTES : SAFETY RULES.

Electrolytes used in EXXELIA^{SIC SAFCO} capacitors are manufactured by EXXELIA^{SIC SAFCO}. Main solvents are generally γ butyrolactone and ethylene glycol, very stable high boiling point solvents. Ionic conductive salts in electrolyte induce a very weak acidity (pH 5 to 7).

8.7. ENVIRONMENT.

- There is no possibility to produce gaseous emissions of nitrogen oxides or liquid emissions of nitrites or nitrates during the manufacture process.
- There is no possibility to produce liquid emissions or salts coming from dangerous metals such as mercury, hexavalent chromium or cadmium and from poisons such as arsenic or cyanides.

Accessories not made in aluminum, ring, screw, are also plated in anticorrosion processes without cadmium.

EXXELIA^{SIC SAFCO} is always involved in this security field particularly in using whenever it's possible chemicals for electrolyte, without well-known risks.

- Dimethylformamide (DMF) dangerous solvent forbidden in several uses is completely excluded by EXXELIA^{SIC SAFCO}, since 1990.
- There is no halogen compound such as chlorofluorocarbon (CFC or FCKW in german) or polychlorobiphenyl (PCB-Pyralene) or pentabromodiphenylether or octabromodiphenylether.

There is neither benzene, toluene or phenyl compound nor explosive such as picric acid, nor asbestos in plastic covers.

All the capacitors made by EXXELIA^{SIC SAFCO} since 1991, can be scrapped or used in raw materials recycling processes with-out special care.

EXXELIA^{SIC SAFCO} aluminum capacitors with non solid electrolyte are particularly suitable for different kinds of environment taking in account severity increasing laws.

European directives 2003/11/EC, 2002/96/EC (WEEE) and 2002/95/EC (RoHS) applies to all EXXELIA^{SIC SAFCO} capacitors including every solder type, manufactured with pure tin coated pins or wires, since at least January 2006.

EXXELIA^{SIC SAFCO} capacitors do not contain any carcinogen, mutagen and substance toxic for reproduction in accordance with 1907/2006/EC (REACH) European directive target.

Mounting and insulating parts

STUD FIXING : FELSIC BD

Steel nut, spring washer and insulating washer are delivered loosely with the capacitor.

STANDARD MOUNTING WITH :

Insulating washer and steel nut

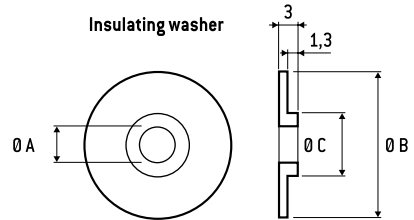
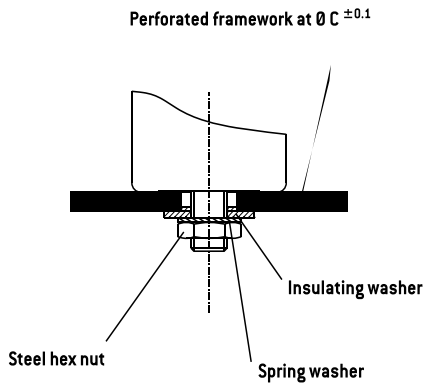

Ø Capacitor	Dimension (mm)				Code
	M	Ø A	Ø B	Ø C	
36	8	8,4	25	18,5	A 691060
51 - 77	12	12,5	30	21,5	A 691061
90	12	12,5	35	21,5	A 691062

Insulating plastic nut with or without insulating washer

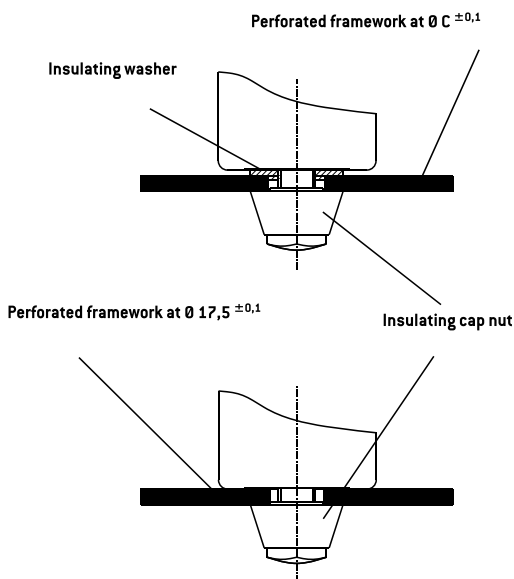

Insulating cap nut

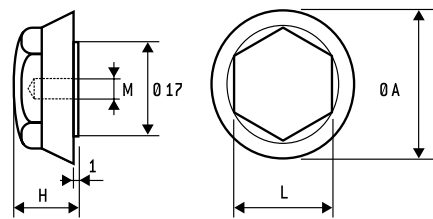

M	Dimension (mm)				Max. torque	Code
	Ø A	H	L			
8	25	15	17	3 Nm	A 691070	
12	30	20	19	7 Nm	A 691071	

Ring - clip mounting : FELSIC LP

Ring clips shall be ordered separately.
Tightening screws and nuts are supplied loosely.

Plastic cap on bracket

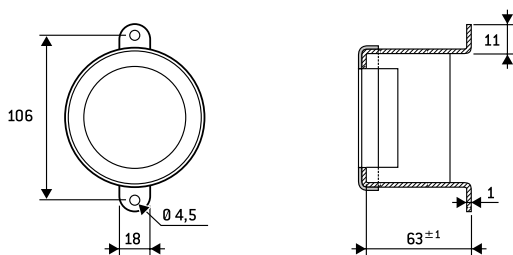

FELSIC 85 LP FELSIC 105 LP	Code
Metal bracket	A691055
Plastic cap	A691065

General technical data

Ring - clip mounting : FELSIC BC

Ring clips shall be ordered separately.

Tightening screws and nuts are supplied loosely.

FELSIC BC - Metal ring-clips

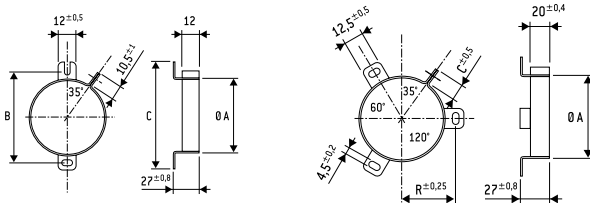

Ø A Cap.	B	C	Code	Ø A Cap.	B	C	Code
36	54	63	A 691901	51	33,5	11,8	A 691905
				66	39	10,5	A 691913
				73	44	10,5	A 691914
				77	44,5	10,5	A 691907
				90	53,3	11,8	A 691915

Stirrup mounting : CUBISIC LP

Stirrups shall be ordered separately.

Tightening screws and nuts are supplied loosely

Salt mist endurance of screws and mounting accessories :
minimum 96 h (IEC 600 68-2-11)

CUBISIC /CUBISIC LP - Metal bracket

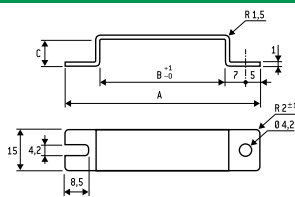

Ø A Cap.	A	B	C	Code
45x12	69	45	10	A 691057
35x16	59	35	14	A 691059

PACKAGING

1. PACKAGING AND WEIGHT UNITS.

1.1. Capacitor with screw terminals

Case dimensions				Unit weight *
Ø	H			(g)
36	47	52	53	70
36	60			79
36	80	81		100
36	104	105		120
51	47			80
51	62	63		105
51	81	82		190
51	104	105		260
51	112			270
51	144			370
66	104	105		430
66	112			460
73	104	112		600
73	144			680
77	104	105		620
77	144	145		860
77	200			1300
77	220	221		1400
90	67			600
90	144	145		1400
90	200			1800

* Unit weight = typical values

Possible variations of = ± 25 % according to different voltage and capacitance.

1.2. Radial solder types

Case dimensions		ALSIC	SNAPSIC	Case dimensions		ALSIC	SNAPSIC
Ø (mm)	H (mm)	Weight* (g)	Weight* (g)	Ø (mm)	H (mm)	Weight* (g)	Weight* (g)
10	16	1,8		35	30		50
				35	40		50
12,5	21	4,5		35	45		52
12,5	24	5		35	50		60
				35	75		95
16	25	8,2		35	100		125
22	25		15	40	40		65
22	30		17	40	50		100
22	40		18	40	75		130
				40	100		170
25	25		17	45	21		50
25	30		20	45	25		60
25	35		22	45	30		73
25	40		25	45	35		85
25	45		28	45	45		110
25	50		30	45	75		180
				45	100		240
30	25		28				
30	30		30				
30	35		30				
30	40		40				
30	45		45				
30	50		50				

Case dimensions			CUBISIC
I	L	H	weight (g)
35	35	16	30
35	50	16	40
45	35	12	30
45	50	12	45
45	75	12	60

* Unit weight = typical values

Possible variations of = ± 25 % according to different voltage and capacitance.

1.3. Axial types

Case dimensions		PRORELSIC	PRORELSIC	SICAL CO 42
Ø (mm)	H (mm)	Unit weight * (g)	PROMISIC (g)	SICAL (g)
6,5	15		1,6	
6,5	19		1,8	1,8
8,5	19		2,3	2,3
10	19		2,8	2,8
10	25		3,5	3,5
10	28		3,8	
12	25		5	
12	30		5,4	5,4
14	30		6,9	6,9
14	41		9,5	
16	30	7,7		7,7
18	35	13,6		
18	40	15,3		15,3
21	40	19,5		19,5
25	40	28		28
25	50	35		35
25	75	56		56

* Unit weight = typical values

Possible variations of = ± 25 % according to different voltage and capacitance.

General technical data

2. PACKAGING ON TAPE

2.1. Axial types

Dimensions and tolerance (in mm) in accordance with IEC 60 286-1

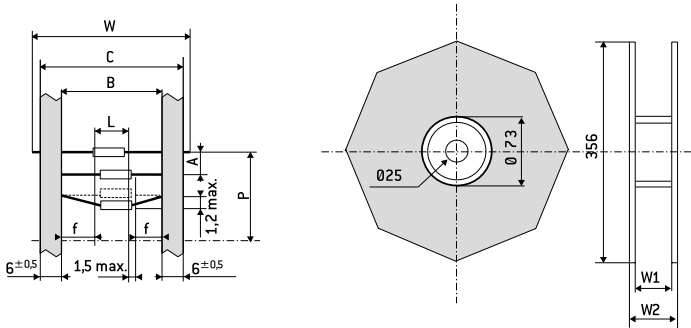

Dimensions									
D	L max.	B	A	P	C max.	W ₁	W ₂ max.	W	n ⁽²⁾
6,5	20	73±1,5	10±1,5	± 2	87,5	93	106	85±1,5	1000
8,5 ⁽¹⁾									750
10 ⁽¹⁾									400
12 ⁽¹⁾	32	73±1,5	15±1,5	± 3	87,5	93	106	85±1,5	400
14 ⁽¹⁾									200

- (1) On tape only on request
- (2) n = number of capacitors per reel.

White positive tape f : > 20 mm
P: 10 space

2.2. ALSIC IR - ALSIC 145

Dimensions and tolerance (in mm) in accordance with IEC 60 286-2.

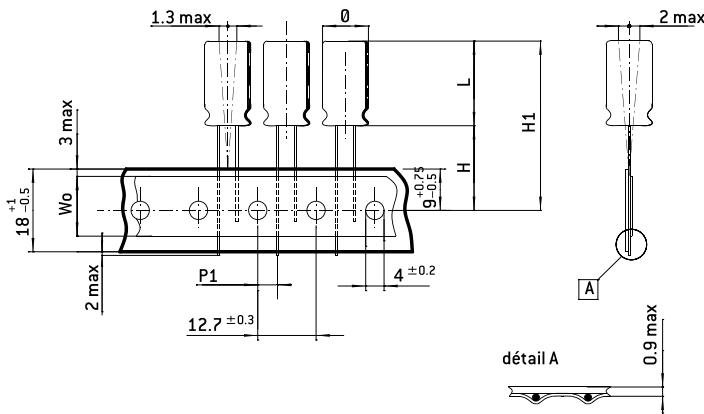

Dimensions (mm)					
Ø	L	H ₁ max.	W ₀	P ₁	H
10	16	46,5	13	3,85	19±1

Fan fold packaging (Ammopack)
Number of capacitors : 1000

